



WHAT IS YOUR FIRMS TRIANGULAR PROFILE?

By the very nature of my employment contract, I must adapt my professional interests and pursuits to a tripartite audience. One day my mind is oriented toward research and an audience of professional colleagues. During such times, my thoughts dwell on the abstract, the theoretical, and an attempt to create "a net addition to knowledge." Perhaps the very next day, I may find myself in a classroom confronting an audience of university students. Here I must concern myself with the "transfer of knowledge" and related essences of the learning process itself. On the third day, I may find myself hundreds of miles from the campus speaking to an audience of agribusiness managers. Here I must direct my efforts to the "application of knowledge."

The Problem

This process of adding to, transferring, and applying knowledge is not always well-defined as I would like. Yet the task is an enjoyable and challenging one. For example, it is during the third day noted above that the challenge becomes one of taking a theoretical concept and illustrating its practical application. Beyond a doubt, that subject matter area that I find most difficult to convey in a practical sense relates to the process of evaluating a firm's performance. In the abstract, it is quite easy to establish a set of criterion by which firm performance can be measured. Even in the classroom it is not too difficult to obtain student agreement on those characteristics which differentiate "good" from "bad" firm performance. Agribusiness managers, however, are much more demanding. They realize that one

year's profit or loss is a very poor indicator of performance. Furthermore, they can cite numerous practical examples where any one of the standard industry measures has proved to be misleading. As a result, in measuring the performance of his own firm, the average manager reviews such assorted factors as total sales, markets, wages paid, margins, etc. After a totally undefined process of mental gymnastics, he proclaims his firm to be "healthy," "faced with a temporary crisis," "in the process of recovery," or in some other ambiguous state. In his own mind, the manager has reviewed those elements which are important in determining the present and future quality of his firm's operations. Yet no systematic or uniform process of evaluation has been established, and final conclusions may vary from one individual to another.

Surely there exists, theoretically or in the abstract, an evaluation procedure that is both systematic and uniform. Further, the theory must be simple and realistic. It must have such practical appeal that those in my agribusiness management audience are encouraged to at least experiment with it.

The purpose of this paper is to develop and describe a systematic, uniform, and practical process for managerial evaluation of firm performance. The process itself shall be called "Profile Triangulation."

Major Profile Elements

In the field of education, we use the results of college entrance examinations to prepare what is called a "student profile." This profile is used to evaluate a student's present capabilities and future potential in various basic academic disciplines. To be certain,

the process of generating a student's profile is not perfect. However, few would deny that the process is systematic, uniform, and useful. It would seem logical to me that business firms, like students, could be measured, and profiles developed – profiles that would not be perfect, but would prove useful to management in assessing firm performance and formulating future strategies.

My proposed system of profile triangulation rests on the assertion that all the major aspects of firm performance can be classified into one or more of the following three basic categories:

- a) The return on investment in the business (R.O.I).
- b) The present level and growth potential of the firm's sales volume and the market in which it operates.
- c) The relative size of the firm's involvement in that market (market share).

The basis for the assertion above is linked to the total interdependence of the three categories. For example, it is possible for a firm to find itself in a market with a tremendous growth potential. But if the firm's involvement in that market is not at a significant level, then its involvement alone is not a meaningful measure of performance. Nor would it be desirable for a firm to enter a growing market, capture a significant market share, yet maintain an unacceptable level of R.O.I. Each of the three elements affecting firm performance is important, but only as it relates to the other two.

Interdependence and Triangulation

There exists only a single geometric design that fully illustrates the total interdependency of three distinct elements. It's a triangle. Each side of a triangle is totally dependent on support from the other two adjacent sides. Remove or fracture one side of a triangle and the triangle collapses and ceases to exist.

You may also recall a theorem in geometry that states, "a triangle may be described when one side and its two adjacent angles are known." We shall now use these unique triangle characteristics to devise a visual illustration of a firm's operational performance. Returning to our three major performance categories, let's first construct a triangle base line that represents the firm's current sales volume. Next, we allow the left-hand adjacent angle to represent the firm's market share. Finally, we allow the right-hand adjacent angle to represent the firm's R.O.I. With the base line and its two adjacent angles now known, a triangle can now be constructed which uniquely illustrates the performance characteristics of the firm being assessed, see Figure 1, a-b-c.

Figure 1. Triangle Construction

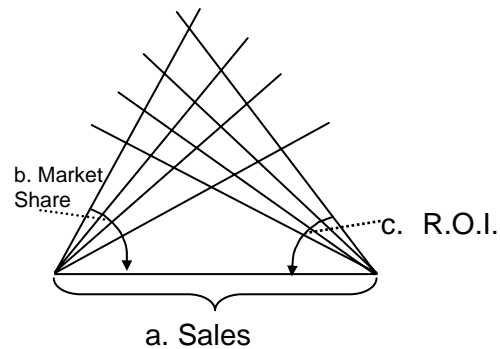

At this point it should be apparent that an infinite number of triangles can be created in this manner, depending on your selection of the scales between (a) length of base line per dollar of sales, (b) the slope (in degrees) of the left adjacent angle per market share percent, and (c) the slope (in degrees) of the right adjacent angle per R.O.I. (in percent). Yet, given these possibilities, once the scales have been selected, there exists only one triangle that will be described by the unique performance statistics of any one business firm.

Triangular Construction

In constructing the triangle, the selection of scales for the base line and adjacent angles

is most important. Since any judgment of performance must be relative measure, some standard of comparison must first exist before any improvements in performance, or lack thereof, can be identified. Hence our first step in triangulation requires that the firm in question identify those performance data which it considers to be "ideal" or "optimum."

For example, let's take the hypothetical firm, A.B.C. Corporation. A.B.C.'s management is about to launch a 5-year expansion program. By 1977, year end, A.B.C. would like to reach a sales volume of \$2 million, capture 20 percent of total market sales, and achieve a 10 percent R.O.I. In the view of A.B.C. management, these three performance goals represent their concept of the "ideal" position for A.B.C. to be in by the end of their 5-year program. Hence all firm movements during the 5-year period can now be judged as being toward or away from the ideal. Using the ideal performance data, scales can now be selected and ideal firm's triangular profile constructed. For ease of construction and later visual comparison, it would seem wise to construct the ideal firm's profile as an equilateral triangle. For example, A.B.C.'s ideal 1977 profile might look like Figure 2 below -- where the scales selected would be 1 inch -- \$1 million sales, 3° left adjacent angle = 1 percent market share and 6° right adjacent angle = 1 percent R.O.I.

Figure 2. A.B.C.'s Ideal Profile - 1977

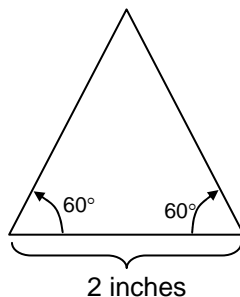

Using the scales selected above, the second step calls for A.B.C. management to construct a profile of its firm as it exists at the present (1972). Suppose A.B.C.'s present performance data include an annual sales volume of \$1.5 million, a 10 percent market

share, and a 6 percent R.O.I. Hence its current triangular profile would approximate Figure 3 below:

Figure 3. A.B.C. 1972 Triangular Profile

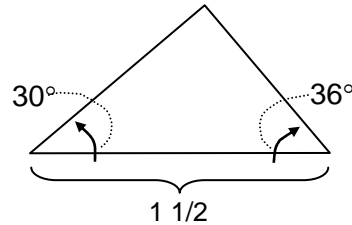

By now it should be obvious that a combination of the area and the shape of the firm's triangular profile is representative of that firm's performance. Although the area or the shape alone is unitless and may also be meaningless, together they provide a basis for measuring progress and improvement in performance when compared with the size and shape of the "ideal." This simple visual vehicle now provides management with a practical means for identifying areas of opportunities as well as a basis for forecasting the likely impact of future management strategies.

Triangular Expansion Methodology

In our illustration, A.B.C. is shown to confront the problem of expanding its 1972 level of operations, while also improving its performance by 1977. Visually, of course, A.B.C. desires to increase the area and shape of its 1972 profile to more closely approximate its ideal 1977 profile.

Increasing the area of their triangular profile could be accomplished in the following three ways: (1) by single action and direction, (2) by multiple actions in a single direction, or (3) by multiple actions in a combination of directions. The choice of action and direction is, of course, the dilemma faced by all management planners. However, with the knowledge of profile triangulation, the manager is now better equipped to cope with the dilemma. The shape of the profile

provides management with valuable clues to the direction in which he should plan.

Using our illustration, let's first assume that management finds the 1972 levels of market share and R.O.I. to be somewhat rigid. To substantially increase market share would be to invite government investigation on the grounds of suspicion of monopolistic practices. To substantially increase R.O.I. would be an open invitation for new competitors to enter the market. Because of this built-in rigidity of adjacent angles, the only way management can increase its profile area is to review current total market growth and implement those management actions designed to increase A.B.C.'s sales in proportion to that growth. For example, if the total market is growing noticeably, a plan to retain current levels of market share and R.O.I., automatically will increase the base line of the profile and, consequently, its entire area: See Figure 4.

Figure 4. Profile Adjustment Under Natural Market Growth

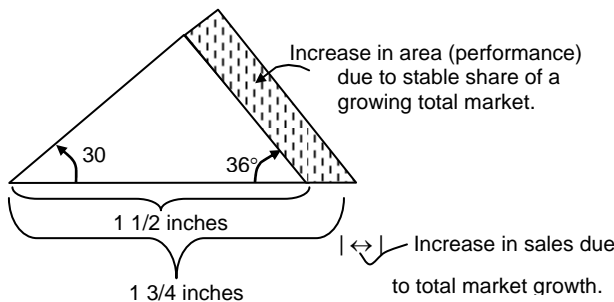

What if the growth in the total market is negligible or declining? In this situation, management must design a plan which somehow broadens the relevant total market, while at the same time maintaining its levels of market share and R.O.I. One such plan would be the development of new products, thereby expanding the relevant total market. At the beginning, however, entering new markets with new products will likely result in at least a temporary reduction in both market share and R.O.I.; i.e., you would enter the new market at a low level of sales penetration

and new product development costs would reduce R.O.I. The initial result of this plan is illustrated in Figure 5 -- where firm sales increase, market share decreases, R.O.I. decreases, profile areas are both lost and gained -- the net result of which could be positive, negative, or neutral.

Figure 5. Profile Adjustment Under New Product Development

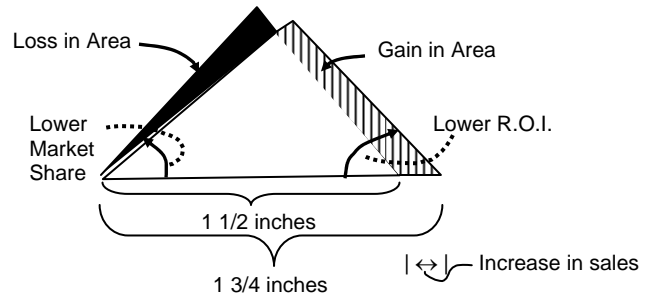

Once the new products have been developed and the new markets entered, management now faces more opportunities for profile expansion than if it had chosen to accept the status quo of Figure 4. For example, efforts may now be taken to expand market share and R.O.I. to previous levels, and thereby increase profile area to that attained under conditions of a growing total market (Figure 4): See Figure 6 below.

Figure 6. Profile Adjustment Under Recapture of Market Share and R.O.I.

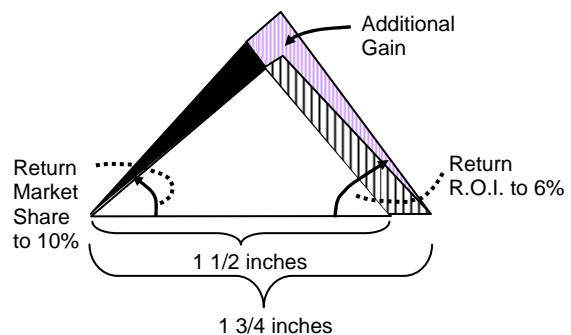

Relative Opportunities

Now suppose that instead of the profile shown in Figure 3, A.B.C. found that its 1972

profile more closely approximated that shown in Figure 7 below:

Figure 7. Alternative 1972 Profile -- A.B.C.

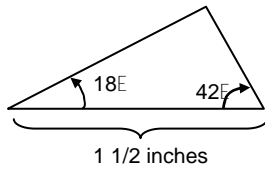

Here, the sales volume is depicted at \$1.5 million, market share is comparatively lower at 6 percent, while R.O.I. is comparatively higher at 8 percent. How does the firm's performance, as depicted in Figure 7, compare with that depicted in Figure 3? Actually, the comparison is a difficult one to make. Yet such a comparison can be made by considering the relative opportunities available to the firm under the two sets of conditions. Faced with Figure 3 conditions, A.B.C. had two alternatives, i.e. grow with the market or add new products. Confronted with Figure 7 conditions, however, their alternatives include the two above, plus others. For example, A.B.C. could add new products, grow with the market, or implement a sales program designed to increase market share. If A.B.C. succeeds in increasing its market share of a growing total market, the synergistic effect of this combination creates an even greater increase in profile area and supports an adjustment in profile "shape" which is a noticeable move in the direction of the ideal (Figure 2): See Figure 8 below.

Figure 8. Profile Alternative Opportunities

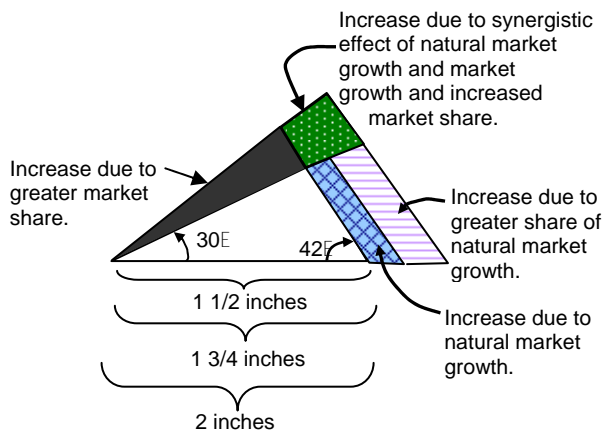

Selecting the Appropriate Management Strategy

Now let's assume A.B.C.'s 1972 profile approximated Figure 9. Here, the profile indicates \$1.5 million sales, 10 percent market share and 2 percent R.O.I. Obviously R.O.I. requires substantial improvement.

Figure 9. Third 1972 A.B.C. Profile

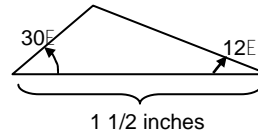

Improving R.O.I., however, should not be the sole concern of A.B.C. management as other strategies would also increase the area of the profile. For example, the area could be increased by sacrificing some market share in favor of an increased R.O.I. In other words, when considering alternative management strategies, all three elements of the profile must be considered. Each strategy's effect on each element of the profile can be assessed by appropriately adjusting the 1972 profile to depict graphically its effect. For example, let's assume that total market sales are increasing at such a rate that they will total about \$20 million in 1977. If A.B.C. maintains its current market share (10 percent) its sales will total \$2 million in 1977. Hence, by 1977, A.B.C.'s profile would contain a larger area than that shown in Figure 9, but would have the same general shapes: See Figure 10. Now let's evaluate alternative action programs.

Figure 10. 1977 A.B.C. Profile

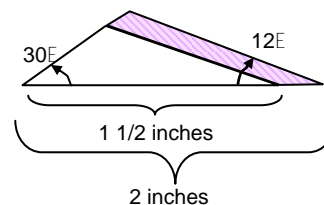

It might be determined that the breadth of the product line required to maintain the existing market share is so costly as to depress the

R.O.I. Management, therefore, might consider dropping some low margin items from its total product line. It's estimated that this action would decrease sales 10 percent, but increase R.O.I. to 4 percent. Under these conditions, A.B.C.'s 1977 profile would adjust as shown in Figure 11. A.B.C.'s 1977 sales would now total \$1.8 million rather than \$2 million. Because of these lower firm sales, A.B.C.'s market share would drop from 10 percent to only 9 percent of the 1977 total market sales of \$20 million. There is a loss in profile area attributable to these two adjustments.

Figure 11. Alternative 1977 Profile

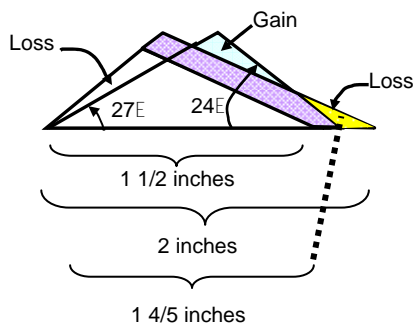

However, with R.O.I. rising to the 4 percent level, an appropriate area gain is also generated. In fact, as is clearly illustrated by the adjustments in Figure 11, area of gain exceeds the areas of loss such that total area profile shows a net area gain. Thus it appears that this strategy is best for the company even though sales volume and market share have been sacrificed to a degree.

Generalized Rules

In the immediately preceding illustration, a management strategy which resulted in the largest net increase in the firm's profile area was shown to be preferred. In addition, you will note that not only did the profile area increase, the shape of the final profile more closely approximated that of the equilateral "ideal." It can be shown that a generalized rule exists which states, "That management

strategy, which when used to adjust the firm's current triangular profile, results in the largest net increase in profile area *and* the closest visual approximation of that firm's equilateral ideal profile, shall be preferred." By using this rule and the process of profile triangulation, a firm manager can: (1) measure firm performance, (2) detect relative improvements in or deterioration of firm performance, and (3) select (and apply) that action (or strategy) that will result in operational performance most closely approximating his views of the ideal.

Another Application

As shown, profile triangulation does provide a systematic, uniform, and practical procedure for firm performance evaluation. Yet it has other possible applications. It could prove equally valuable as an aid in evaluating the compatibility of two firms considering the possibility of merger or acquisition. By reviewing the profiles of the two firms, separately, and the profile of the two-firm composite, it would become obvious whether strengths were being added to strengths, weaknesses to weaknesses, or strengths to weaknesses such that a net gain (or loss) in performance would evolve.

Final Note

Because of the individual selection of performance data scales, profile triangulation cannot be used as a definitive measure of one firm's worth against that of another. It can, however, be used as a basis for judging future performance against that of the present. It can also illustrate where opportunities lie and which are the more attractive to agribusiness managers.

Ken D. Duft

Ken D. Duft
Extension Marketing Economist